



US 20160204366A1

(19) **United States**

(12) **Patent Application Publication**

Zhang et al.

(10) **Pub. No.: US 2016/0204366 A1**

(43) **Pub. Date: Jul. 14, 2016**

(54) **FLEXIBLE DISPLAY PANEL WITH BENT SUBSTRATE**

(52) **U.S. Cl.**

CPC *H01L 51/0097* (2013.01); *H01L 51/004* (2013.01); *H01L 27/3276* (2013.01); *H01L 51/5253* (2013.01); *H01L 2251/5338* (2013.01); *H01L 2251/558* (2013.01)

(71) Applicant: **Apple Inc.**, Cupertino, CA (US)

(72) Inventors: **Zhen Zhang**, San Jose, CA (US); **Yi Tao**, San Jose, CA (US); **Paul S. Drzaic**, Morgan Hill, CA (US); **Joshua G. Wurzel**, Sunnyvale, CA (US)

(57) **ABSTRACT**

(21) Appl. No.: **14/987,129**

(22) Filed: **Jan. 4, 2016**

Related U.S. Application Data

(60) Provisional application No. 62/102,284, filed on Jan. 12, 2015.

Publication Classification

(51) **Int. Cl.**
H01L 51/00 (2006.01)
H01L 51/52 (2006.01)
H01L 27/32 (2006.01)

A display may have an array of organic light-emitting diodes that form an active area on a flexible substrate. Metal traces may extend between the active area and an inactive area of the flexible substrate. Display driver circuitry such as a display driver integrated circuit may be coupled to the inactive area. The metal traces may extend across a bend region in the flexible substrate. The flexible substrate may be bent in the bend region. The flexible substrate may be made of a thin flexible material to reduce metal trace bending stress. A coating layer in the bend region may be provided with an enhanced elasticity to allow its thickness to be reduced. The flexible substrate may be bent on itself and secured within an electronic device without using a mandrel.

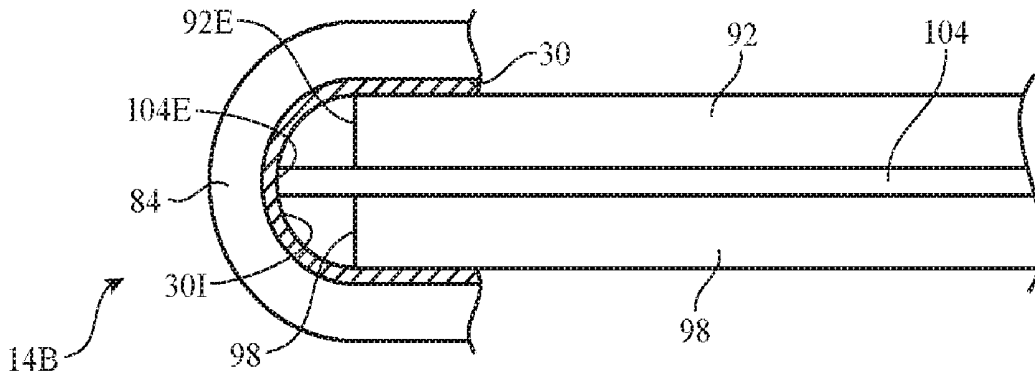

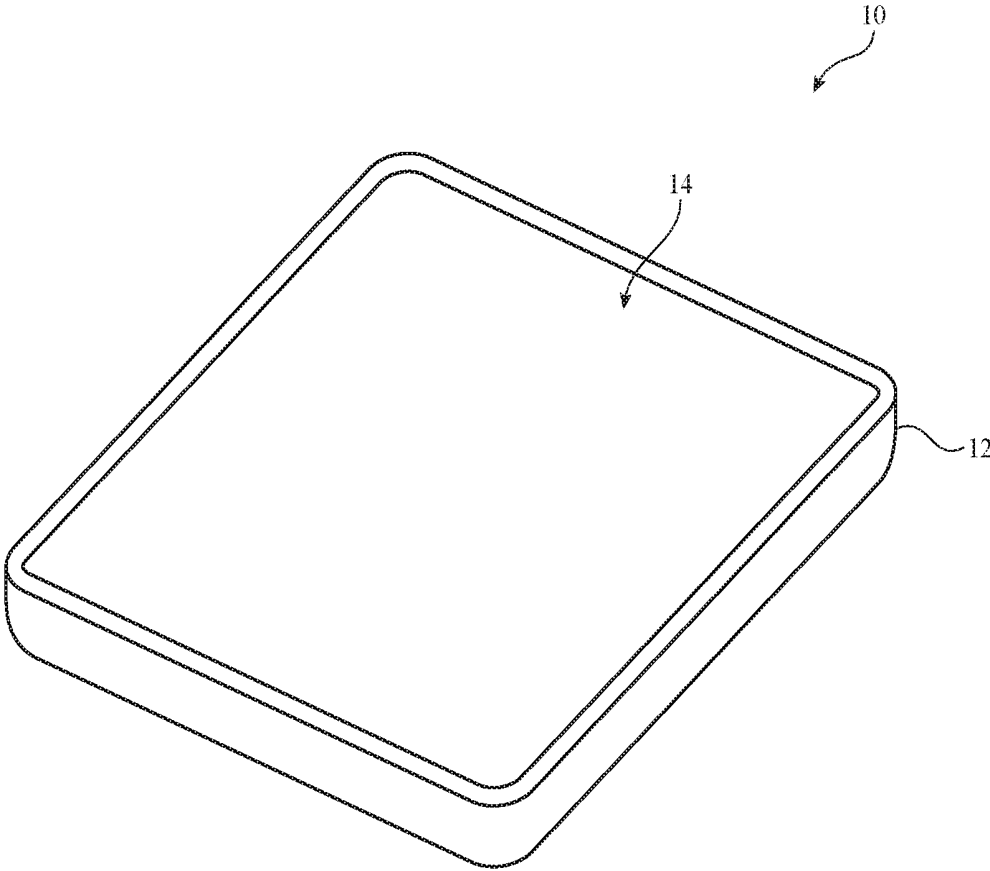

FIG. 1

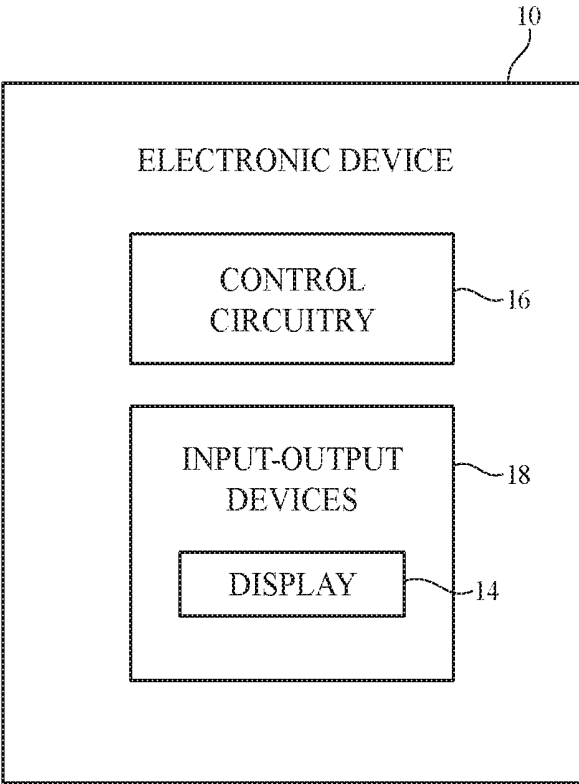

FIG. 2

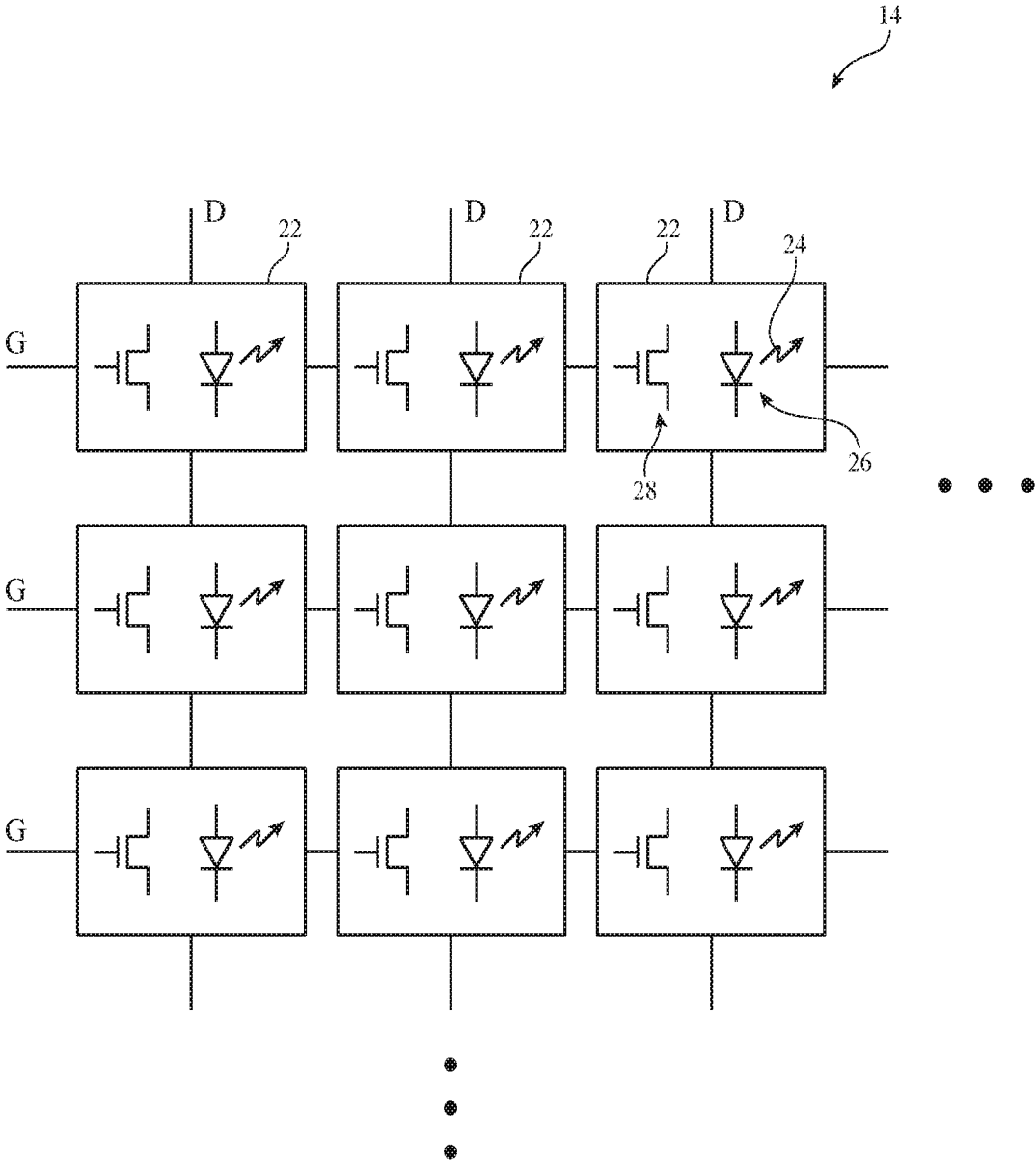

FIG. 3

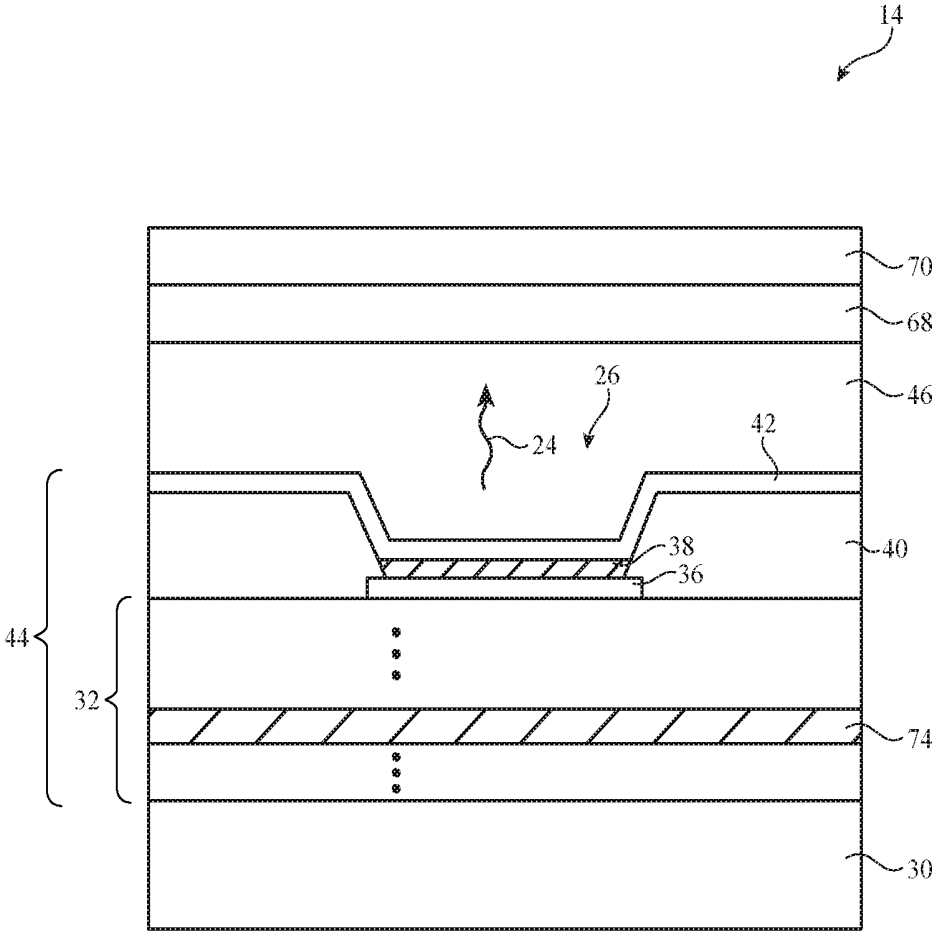

FIG. 4

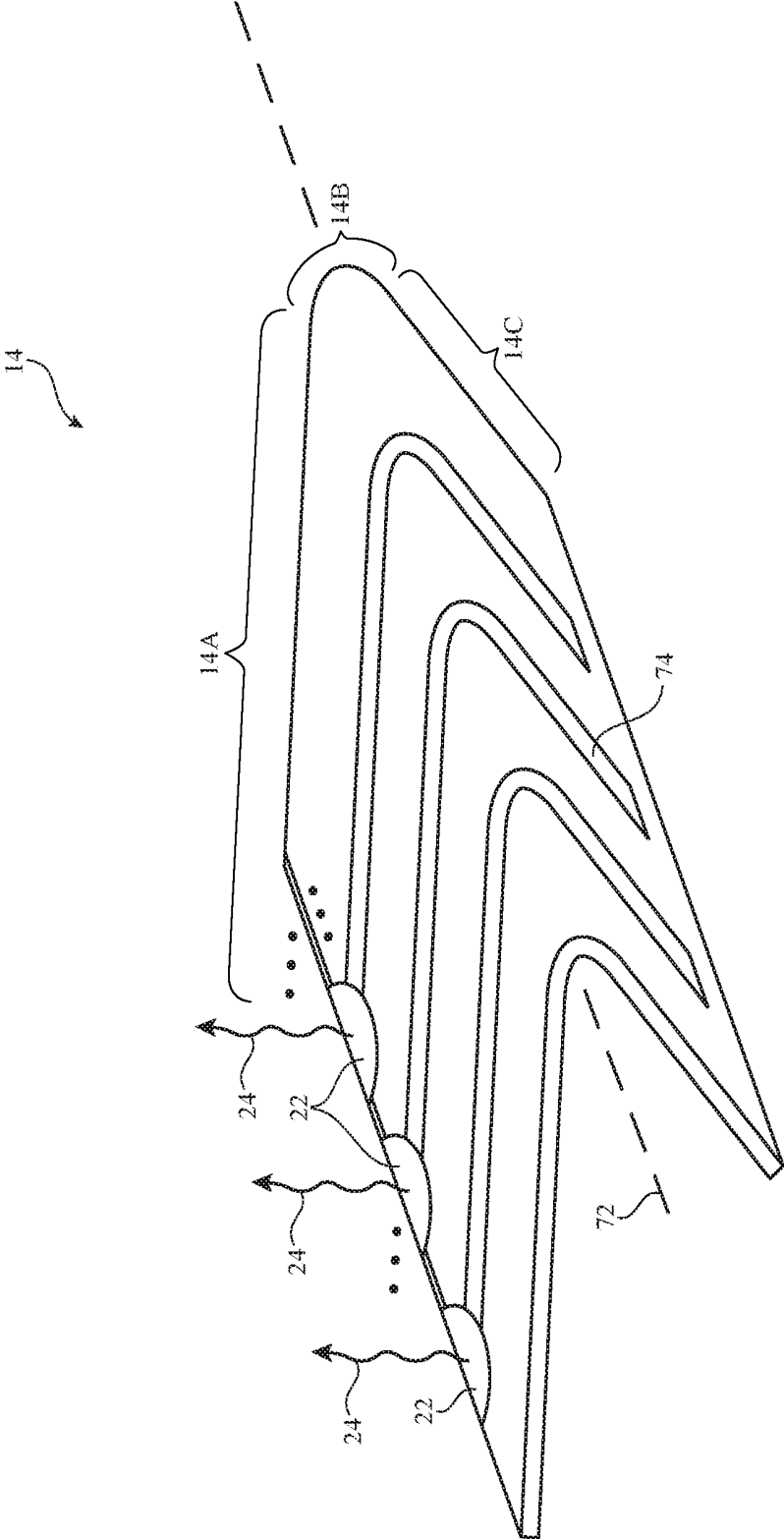

FIG. 5

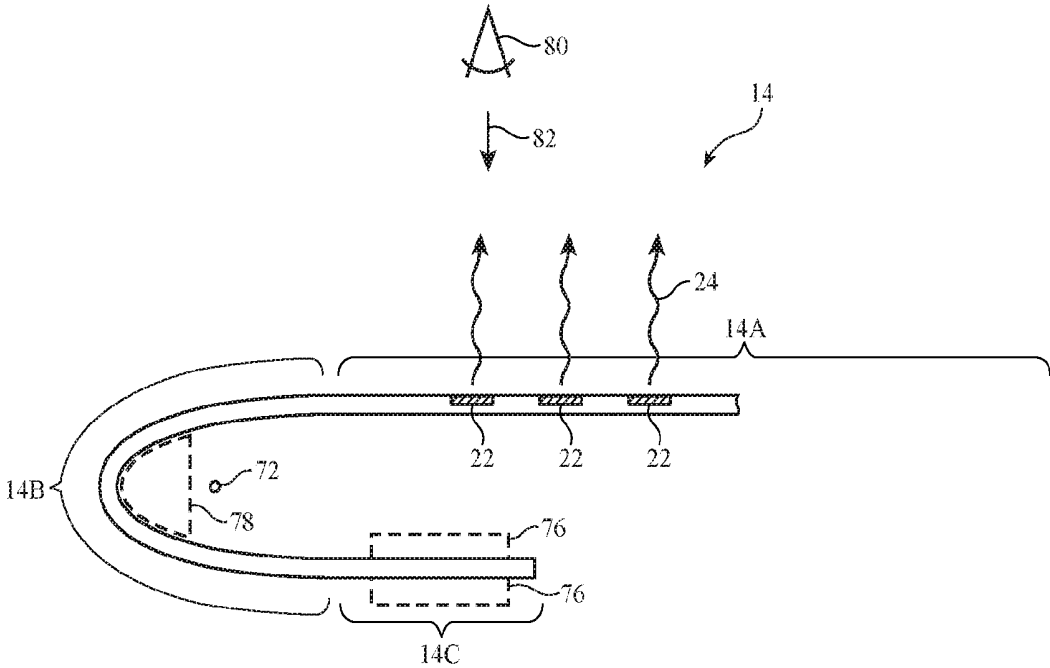

FIG. 6

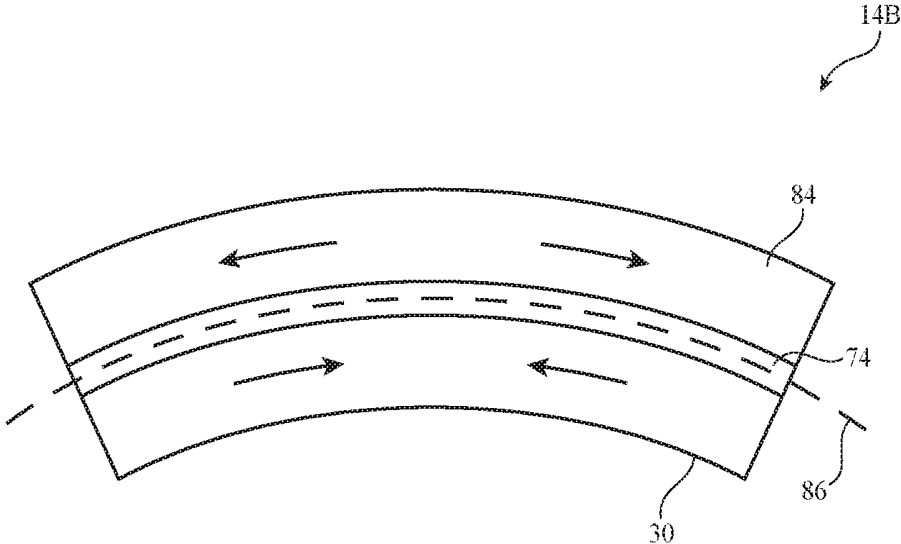

FIG. 7

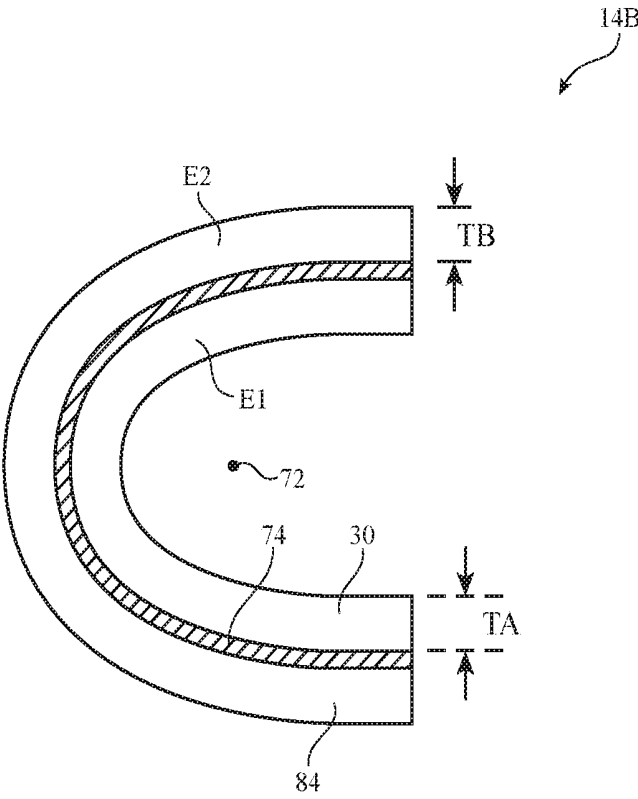

FIG. 8

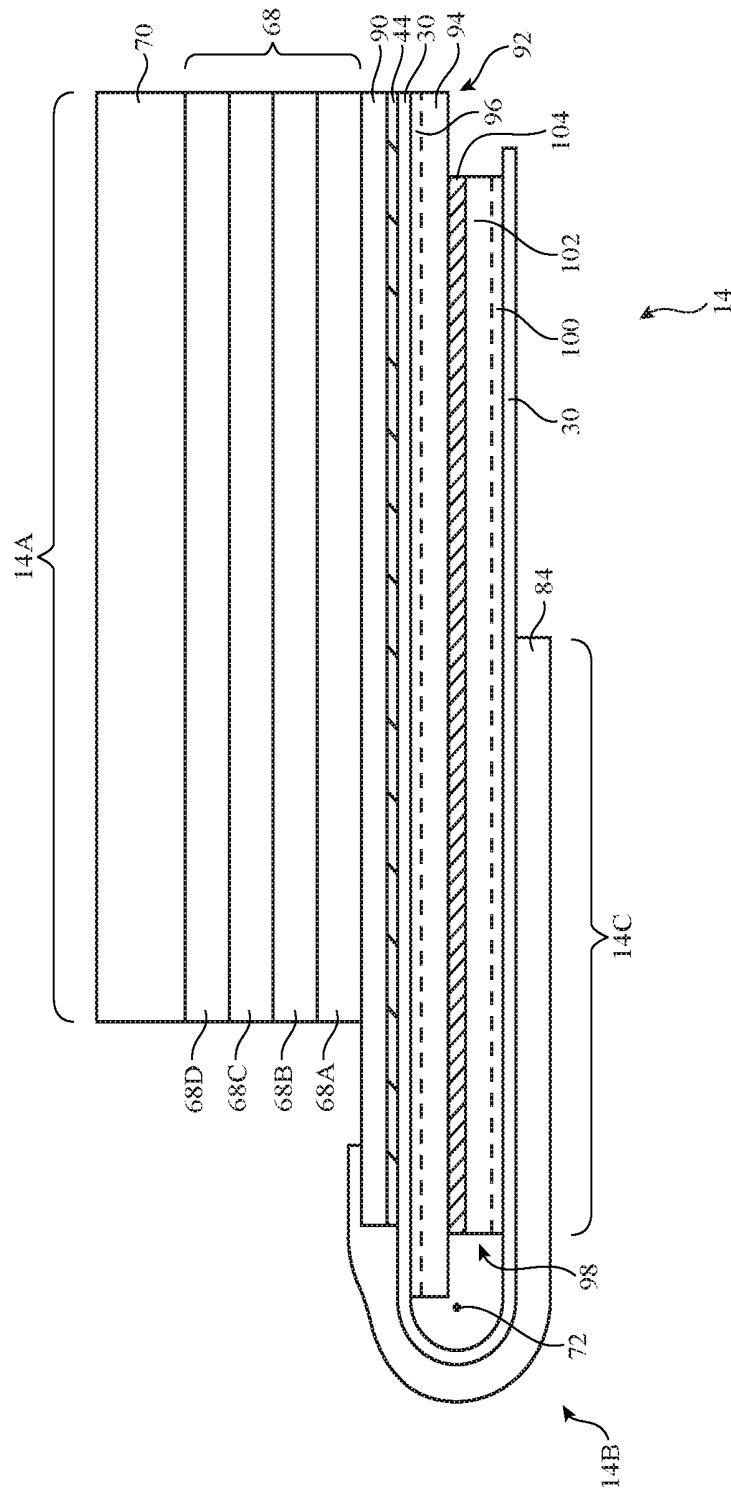

FIG. 9

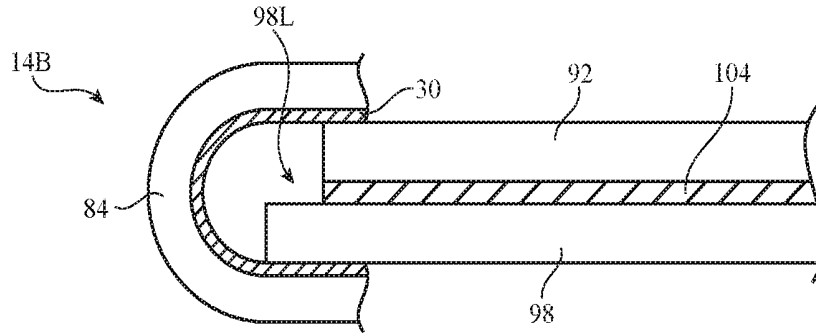

FIG. 10

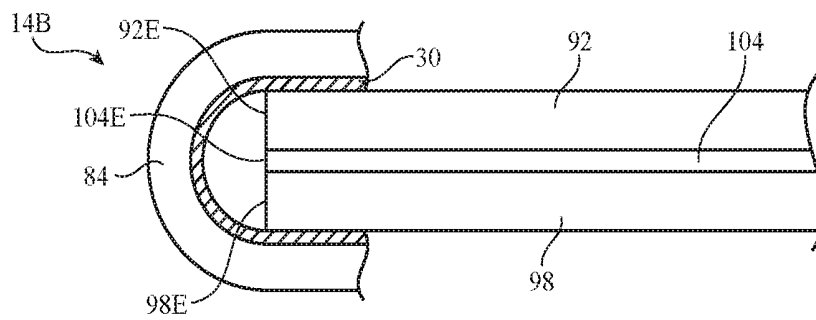

FIG. 11

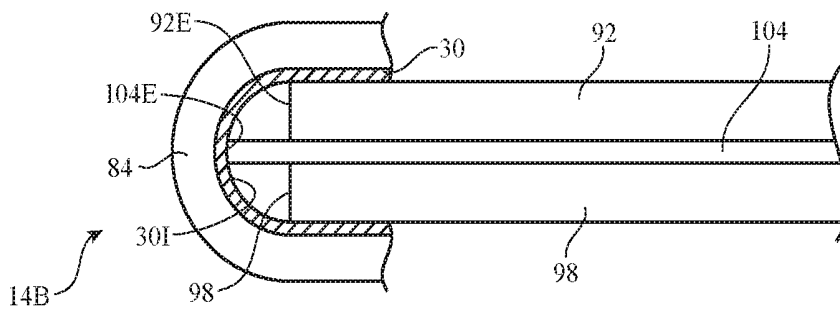

FIG. 12

FLEXIBLE DISPLAY PANEL WITH BENT SUBSTRATE

[0001] This application claims the benefit of provisional patent application No. 62/102,284, filed Jan. 12, 2015, which is hereby incorporated by reference herein in its entirety.

BACKGROUND

[0002] This relates generally to electronic devices with displays, and, more particularly, to displays with bent portions.

[0003] Electronic devices often include displays. Displays such as organic light-emitting diode displays may be formed on flexible substrates. Displays with flexible substrates may be bent. For example, it may be desirable to bend an edge of a display to hide inactive display components along the edge of the display from view.

[0004] The process of bending a display can create stresses within the structures of the display. For example, bent metal traces may become stressed. Stress-induced damage such as cracks may adversely affect display reliability.

[0005] It would therefore be desirable to be able to provide improved displays with bent portions.

SUMMARY

[0006] A display may have an array of organic light-emitting diodes that form an active area on a flexible substrate. Metal traces may extend between the active area and an inactive area of the flexible substrate. Display driver circuitry such as a display driver integrated circuit may be coupled to the inactive area. The metal traces may extend across a bend region in the flexible substrate. The flexible substrate may be bent in the bend region.

[0007] The flexible substrate may be made of a thin flexible material to reduce metal trace bending stress. A coating layer in the bend region may be provided with an enhanced elasticity to allow its thickness to be reduced. The flexible substrate may be bent on itself and secured within an electronic device without using a mandrel.

BRIEF DESCRIPTION OF THE DRAWINGS

[0008] FIG. 1 is a perspective view of an illustrative electronic device having a display in accordance with an embodiment.

[0009] FIG. 2 is a schematic diagram of an illustrative electronic device having a display in accordance with an embodiment.

[0010] FIG. 3 is a top view of an illustrative display in an electronic device in accordance with an embodiment.

[0011] FIG. 4 is a cross-sectional side view of a portion of an illustrative organic light-emitting diode display in accordance with an embodiment.

[0012] FIG. 5 is perspective view of an illustrative display with a bent portion in accordance with an embodiment.

[0013] FIG. 6 is a cross-sectional side view of an illustrative display with a bent portion in accordance with an embodiment.

[0014] FIG. 7 is a cross-sectional side view of an illustrative bent substrate showing how a neutral stress plane may be aligned with metal traces on the substrate using a coating layer in accordance with an embodiment.

[0015] FIG. 8 is a cross-sectional side view of an illustrative display having a flexible substrate with a coating layer that has been bent in accordance with an embodiment.

[0016] FIG. 9 is a cross-sectional side view of an illustrative display with a bent flexible substrate in accordance with an embodiment.

[0017] FIGS. 10, 11, and 12 are cross-sectional side views of illustrative layers in displays with bent flexible substrates in accordance with embodiments.

DETAILED DESCRIPTION

[0018] An illustrative electronic device of the type that may be provided with a display is shown in FIG. 1. Electronic device 10 may be a computing device such as a laptop computer, a computer monitor containing an embedded computer, a tablet computer, a cellular telephone, a media player, or other handheld or portable electronic device, a smaller device such as a wrist-watch device, a pendant device, a headphone or earpiece device, a device embedded in eyeglasses or other equipment worn on a user's head, or other wearable or miniature device, a television, a computer display that does not contain an embedded computer, a gaming device, a navigation device, an embedded system such as a system in which electronic equipment with a display is mounted in a kiosk or automobile, equipment that implements the functionality of two or more of these devices, or other electronic equipment. In the illustrative configuration of FIG. 1, device 10 is a portable device such as a cellular telephone, media player, tablet computer, wrist device, or other portable computing device. Other configurations may be used for device 10 if desired. The example of FIG. 1 is merely illustrative.

[0019] In the example of FIG. 1, device 10 includes a display such as display 14 mounted in housing 12. Housing 12, which may sometimes be referred to as an enclosure or case, may be formed of plastic, glass, ceramics, fiber composites, metal (e.g., stainless steel, aluminum, etc.), other suitable materials, or a combination of any two or more of these materials. Housing 12 may be formed using a unibody configuration in which some or all of housing 12 is machined or molded as a single structure or may be formed using multiple structures (e.g., an internal frame structure, one or more structures that form exterior housing surfaces, etc.).

[0020] Display 14 may be a touch screen display that incorporates a layer of conductive capacitive touch sensor electrodes or other touch sensor components (e.g., resistive touch sensor components, acoustic touch sensor components, force-based touch sensor components, light-based touch sensor components, etc.) or may be a display that is not touch-sensitive. Capacitive touch screen electrodes may be formed from an array of indium tin oxide pads or other transparent conductive structures.

[0021] Display 14 may include an array of display pixels formed from liquid crystal display (LCD) components, an array of electrophoretic display pixels, an array of plasma display pixels, microelectromechanical (MEMS) shutter pixels, electrowetting pixels, micro-light-emitting diodes (small crystalline semiconductor die), organic light-emitting diodes (e.g., a thin-film organic light-emitting diode display), quantum dot light-emitting diodes, or display pixels based on other display technologies. The array of display pixels may display images for a user in active area of display 14. The active area may be surrounded on one or more sides by inactive border regions.

[0022] Display 14 may be protected using a display cover layer such as a layer of transparent glass or clear plastic. Openings may be formed in the display cover layer. For example, an opening may be formed in the display cover layer

to accommodate a button, a speaker port, or other component. Openings may be formed in housing **12** to form communications ports (e.g., an audio jack port, a digital data port, etc.), to form openings for buttons, etc.

[0023] FIG. 2 is a schematic diagram of device **10**. As shown in FIG. 2, electronic device **10** may have control circuitry **16**. Control circuitry **16** may include storage and processing circuitry for supporting the operation of device **10**. The storage and processing circuitry may include storage such as hard disk drive storage, nonvolatile memory (e.g., flash memory or other electrically-programmable-read-only memory configured to form a solid state drive), volatile memory (e.g., static or dynamic random-access-memory), etc. Processing circuitry in control circuitry **16** may be used to control the operation of device **10**. The processing circuitry may be based on one or more microprocessors, microcontrollers, digital signal processors, baseband processors, power management units, audio chips, application specific integrated circuits, etc.

[0024] Input-output circuitry in device **10** such as input-output devices **18** may be used to allow data to be supplied to device **10** and to allow data to be provided from device **10** to external devices. Input-output devices **18** may include buttons, joysticks, scrolling wheels, touch pads, key pads, keyboards, microphones, speakers, tone generators, vibrators, cameras, sensors, light-emitting diodes and other status indicators, data ports, etc. A user can control the operation of device **10** by supplying commands through input-output devices **18** and may receive status information and other output from device **10** using the output resources of input-output devices **18**. Input-output devices **18** may include one or more displays such as display **14**.

[0025] Control circuitry **16** may be used to run software on device **10** such as operating system code and applications. During operation of device **10**, the software running on control circuitry **16** may display images on display **14** using an array of pixels in display **14**.

[0026] Display **14** may have a rectangular shape (i.e., display **14** may have a rectangular footprint and a rectangular peripheral edge that runs around the rectangular footprint) or may have other suitable shapes. Display **14** may be planar or may have a curved profile.

[0027] A top view of a portion of display **14** is shown in FIG. 3. As shown in FIG. 3, display **14** may have an array of pixels **22**. Pixels **22** may receive data signals over signal paths such as data lines **D** and may receive one or more control signals over control signal paths such as horizontal control lines **G** (sometimes referred to as gate lines, scan lines, emission control lines, etc.). There may be any suitable number of rows and columns of pixels **22** in display **14** (e.g., tens or more, hundreds or more, or thousands or more). Each pixel **22** may have a light-emitting diode **26** that emits light **24** under the control of a pixel control circuit formed from thin-film transistor circuitry such as thin-film transistors **28** and thin-film capacitors). Thin-film transistors **28** may be polysilicon thin-film transistors, semiconducting-oxide thin-film transistors such as indium zinc gallium oxide transistors, or thin-film transistors formed from other semiconductors.

[0028] A cross-sectional side view of a portion of an illustrative organic light-emitting diode display in the vicinity of one of light-emitting diodes **26** is shown in FIG. 4. As shown in FIG. 4, display **14** may include a substrate layer such as substrate layer **30**. Substrate **30** may be formed from plastic or other suitable materials. Configurations for display **14** in

which substrate **30** has been formed from a flexible material such as polyimide or other flexible polymer are sometimes described herein as an example.

[0029] Thin-film transistor circuitry **44** may be formed on substrate **30**. Thin film transistor circuitry **44** may include layers **32**. Layers **32** may include inorganic layers such as inorganic buffer layers, gate insulator, passivation, interlayer dielectric, and other inorganic dielectric layers. Layers **32** may also include organic dielectric layers such as a polymer planarization layer. Metal layers and semiconductor layers may also be included within layers **32**. For example, semiconductors such as silicon, semiconducting-oxide semiconductors, or other semiconductor materials may be used in forming semiconductor channel regions for thin-film transistors **28**. Metal in layers **32** may be used in forming transistor gate terminals, transistor source-drain terminals, capacitor electrodes, and metal interconnects.

[0030] As shown in FIG. 4, thin-film transistor circuitry **44** may include diode anode structures such as anode **36**. Anode **36** may be formed from a layer of conductive material such as metal on the surface of layers **32** (e.g., on the surface of a planarization layer that covers underlying thin-film transistor structures). Light-emitting diode **26** may be formed within an opening in pixel definition layer **40**. Pixel definition layer **40** may be formed from a patterned photoimageable polymer such as polyimide. In each light-emitting diode, organic emissive material **38** is interposed between a respective anode **36** and cathode **42**. Anodes **36** may be patterned from a layer of metal. Cathode **42** may be formed from a common conductive layer that is deposited on top of pixel definition layer **40**. Cathode **42** is transparent so that light **24** may exit light emitting diode **26**. During operation, light-emitting diode **26** may emit light **24**.

[0031] Metal interconnect structures may be used to interconnect transistors and other components in circuitry **44**. Metal interconnect lines may also be used to route signals to capacitors, to data lines **D** and gate lines **G**, to contact pads (e.g., contact pads coupled to gate driver circuitry), and to other circuitry in display **14**. As shown in FIG. 4, layers **32** may include one or more layers of patterned metal for forming interconnects such as metal traces **74**.

[0032] If desired, display **14** may have a protective outer display layer such as cover glass layer **70**. The outer display layer may be formed from a material such as sapphire, glass, plastic, clear ceramic, or other transparent material. Protective layer **46** may cover cathode **42**. Layer **46** may include moisture barrier structures, encapsulant materials, adhesive, and/or other materials to help protect thin-film transistor circuitry. Functional layers **68** may be interposed between layer **46** and cover layer **70**. Functional layers **68** may include a touch sensor layer, a circular polarizer layer, and other layers. A circular polarizer layer may help reduce light reflections from metal traces in thin-film transistor circuitry **44**. A touch sensor layer may be formed from an array of capacitive touch sensor electrodes on a flexible polymer substrate. The touch sensor layer may be used to gather touch input from the fingers of a user, from a stylus, or from other external objects. Layers of optically clear adhesive may be used to attach cover glass layer **70** and functional layers **68** to underlying display layers such as layer **46**, thin-film transistor circuitry **44**, and substrate **30**.

[0033] Display **14** may have an active area in which pixels **22** form images for viewing by a user of device **10**. The active area may have a rectangular shape. Inactive portions of dis-

play 14 may surround the active area. For example, signal traces and other support circuitry such as thin-film display driver circuitry may be formed along one or more of the four edges of display 14 that run around the rectangular periphery of display 14 adjacent to the active area. If desired, one or more display driver integrated circuits may be mounted to substrate 30 in the inactive border. For example, a flexible printed circuit on which one or more display driver integrated circuits have been mounted using solder may be attached to the border of display 14. This type of configuration is sometimes referred to as a chip-on-flex configuration and allows display driver circuitry to supply signals to the data and gate lines on display 14.

[0034] To minimize the amount of the inactive border area of display 14 that is visible to a user, one or more edges of display 14 may be bent. As an example, the edge of display 14 to which a display driver circuit is mounted using a chip-on-flex arrangement may be folded under the active area of display 14. This helps minimize visible display borders and reduces the footprint of display 14.

[0035] An illustrative display with a bent edge portion is shown in FIG. 5. As shown in FIG. 5, display 14 has portion 14A (i.e., a planar active area portion that contains the active area of display 14 that is formed by an array of pixels 22), bent portion 14B, and inactive portion 14C. If desired, connectors, display driver integrated circuits or other integrated circuits, flexible printed circuits, and/or other components may be mounted to inactive portion 14C of display 14.

[0036] Metal traces 74 may carry signals between inactive area 14C of display 14 and active area 14A of display 14 (i.e., metal traces 74 may traverse bent portion 14B of display 14). As shown in the cross-sectional side view of the illustrative display of FIG. 6, when bent portion 14B is bent around bend axis 72, portion 14C is folded under portion 14A and is therefore hidden from view by a user such as viewer 80 who is viewing display 14 in direction 82. As shown in FIG. 6, components 76 (e.g., display driver circuitry, etc.) may be mounted on the upper and/or lower surface of display 14 in region 14C. An optional support structure such as mandrel 78 may be used to support display 14 in bend region 14B (e.g., to help establish a desired minimum bend radius in region 14B) or, more preferably, mandrel 78 may be omitted to help minimize display thickness (e.g., by allowing portions 14A and 14C to be mounted more closely together and by allowing the bend radius for region 14B to be reduced).

[0037] When bending display 14 in region 14B, care should be taken to ensure that sensitive display structures do not become damaged. Stresses can be imparted to display structures in a flexible display when the display is bent. For example, metal traces such as metal traces 74 of FIG. 5 that are used to form signal lines that convey signals between display driver circuitry or other circuits in inactive region 14C and pixels 22 in region 14A may be subjected to bending stresses in bend region 14B. To minimize bending stress and thereby minimize cracks in metal traces 74, it may be desirable to align the neutral stress plane of display 14 in bend region 14B with metal traces 74.

[0038] As shown in FIG. 7, when a portion of display 14 is bent in region 14B, some layers such as substrate 30 may be subjected to compressive stress and some layers such as coating layer 84 may be subjected to tensile stress. Neutral stress plane 86 arises where stress has been eliminated by balancing the compressive stress and tensile stress. The shape of neutral

stress plane 86 may be curved in a curved portion of display 14 such as portion 14B of FIG. 7 (i.e., neutral stress plane 86 may have a curved profile).

[0039] The relative thicknesses of substrate 30 and coating 84 and the relative modulus of elasticity values for substrate 30 and coating 84 determine the location of the neutral stress plane within the layers of bent display region 14B. For example, if the elasticity of substrate 30 and coating 84 is the same, neutral stress plane 86 can be aligned with metal traces 74 by ensuring that coating 84 has the same thickness as substrate 30. If, on the other hand, coating 84 has an elasticity that is larger than that of substrate 30, coating 84 need not be as thick as substrate 30 to balance the compressive and tensile stresses.

[0040] FIG. 8 shows how coating 84 may be characterized by a thickness TB and elasticity E2 and how substrate 30 may be characterized by a thickness TA and elasticity E1. The elasticity values E1 and E2 and the thickness values TA and TB may be selected to help ensure that region 14B does not impart undesired stress to metal traces 74. For example, thickness TA may be minimized (e.g., TA may be less than 16 microns, may be 5-15 microns, may be 8 microns, may be 6-12 microns, may be more than 5 microns, etc.) and substrate elasticity E1 may be minimized (e.g., E1 may be less than 9 GPa, may be less than 7 GPa, may be less than 5 GPa, may be 2-3 GPa, may be 1-5 GPa, or may be more than 0.5 GPa) to make flexible substrate 30 more flexible than would otherwise be possible.

[0041] The thickness TB and elasticity E2 of coating 84 may be selected to balance the compressive stress produced when bending substrate 30. With one suitable arrangement, the elasticity E2 may be enhanced to help minimize the magnitude of thickness T2 (and therefore reduce display thickness). The value of E2 may be, for example, about 1 GPa, 0.7 to 1.3 GPa, more than 0.5 GPa, more than 0.7 GPa, more than 0.8 GPa, or less than 2 GPa (as examples). Substrate 30 may be, for example, polyimide and coating 84 may be, for example, a polymer adhesive that is thermally cured or that is cured by application of ultraviolet light.

[0042] FIG. 9 is a cross-sectional side view of an illustrative arrangement that may be used for bending display 14 (e.g., when it is desired to omit mandrel 78 of FIG. 6). As shown in FIG. 9, display 14 may have active portion 14A, bent portion 14B, and inactive portion 14C. In active portion 14A, moisture barrier film 90 may cover the array of organic light-emitting diode pixels 22 and other thin-film transistor circuitry 44 to prevent moisture damage. Layers 68 may be interposed between cover layer 70 and moisture barrier layer 90. Layers 68 may include polarizer 68A (which may be attached to film 90 with pressure sensitive adhesive), optically clear adhesive layer 68B, touch sensor 68C, and optically clear adhesive 68D (as an example).

[0043] In region 14B, coating 84 may be used to adjust the location of the neutral stress plane in display 14 to avoid damage to metal traces 74.

[0044] Portion 14C may be bent under portion 14A and may be secured to the underside of portion 14A using layers such as layers 92 and 98. Layer 92 may include a polymer layer such as polymer substrate layer 94 and a pressure sensitive adhesive layer such as layer 96 that attaches layer 94 to substrate 30. Layer 98 may include a polymer layer such as polymer substrate 102 and a pressure sensitive adhesive layer such as layer 100 that attaches layer 102 to substrate 30. Adhesive layer 96 may be interposed between layers 92 and

98 and may attach layer **94** to layer **102**, thereby attaching the folded portion of display **14** to itself. Layer **96** may be a foam adhesive, a layer of pressure sensitive adhesive, or other suitable adhesive. The thickness of layer **96** may be 30-250 microns, more than 25 microns, or less than 300 microns. The thickness of substrates **94** and **102** may be 100 microns, more than 50 microns, less than 150 microns, 70-130 microns, etc. The thickness of adhesive layers **96** and **100** may be 25 microns, more than 10 microns, less than 50 microns, etc.

[0045] Using an arrangement of the type shown in FIG. 9, display thickness can be minimized by allowing the display to be folded over against itself and attached together with adhesive (i.e., by allowing portion **14C** to be folded and secured against portion **14A** without use of a mandrel).

[0046] FIGS. 10, 11, and 12 are cross-sectional side views of additional configurations for the layers in displays with bent flexible substrates.

[0047] In the example of FIG. 10, layer **92** does not extend outwards as far as layer **98**, so ledge portion **98L** of layer **98** is exposed and the edges of layers **92** and **98** at the bent portion of display **14** are not aligned with each other. Arrangements of the type shown in FIG. 10 may help bend portion **14B** of display **14** with a desired bend profile.

[0048] In the illustrative arrangement of FIG. 11, the edges of layers **98** and **92** (i.e., respective edge surfaces **98E** and **92E**) have been aligned with each other and have been aligned with edge surface (edge) **104E** of adhesive layer **104**. As with the arrangements of FIGS. 9 and 10, the use of this arrangement for layers **98** and **92** may be helpful in adjusting display **14** so that portion **14B** exhibits a desired bend profile.

[0049] In some situations, it may be desirable for edge **104E** of adhesive layer **104** to extend outwardly towards bent portion **14B** of display **14** past edges **92E** and **98E** of layers **92** and **98**. This type of arrangement is shown in FIG. 12. As shown in FIG. 12, adhesive layer **104** may protrude sufficiently far past edges **92E** and **98E** that edge surface **104E** of layer **104** contacts and supports inner surface **30I** of substrate **30**. The use of a protruding adhesive layer such as layer **104** of FIG. 12 may help ensure that bent display portion **14B** exhibits a desired bend profile.

[0050] Although sometimes described herein in the context of flexible displays, substrate **30** may be used to form any suitable devices. For example, circuitry may be formed on substrate **30** in regions **14A**, **14B**, and/or **14C** that forms one or more touch sensors that are free of pixels (i.e., pixels **22** may be replaced by touch sensor electrodes, packaged sensors, or other sensor structures), that forms force sensors, or that forms other electrical components with or without including pixels on substrate **30**. Thin-film circuitry and/or circuitry that forms part of a discrete device (e.g., integrated circuits etc.) may be formed on substrate **30** (e.g., in regions **14A**, **14B**, and/or **14C**) and may include sensors, integrated circuits with sensor circuitry or other sensor structures, input-output circuitry, control circuitry, or other circuitry. If desired, the circuitry on substrate **30** may allow some or all of substrate **30** to serve as a signal cable (e.g., a flexible printed circuit cable that contains signal lines for routing signals between different portions of device **10**). In arrangements such as these, metal traces may extend across bent region **14B** to allow signal to pass between circuitry in regions **14A** and **14C** and, if desired, to route signals to and from circuitry in regions **14B**. The use of a portion of substrate **30** in forming a display is merely illustrative.

[0051] The foregoing is merely illustrative and various modifications can be made by those skilled in the art without departing from the scope and spirit of the described embodiments. The foregoing embodiments may be implemented individually or in any combination.

What is claimed is:

1. A display, comprising:

a flexible substrate;

an array of pixels that form an active area on the flexible substrate;

metal traces that extend from the active area to an inactive area on the flexible substrate across a bend region on the flexible substrate, wherein the flexible substrate is folded over against itself at the bend region so that the active area overlaps the inactive area;

first and second polymer layers interposed between the active area and the inactive area that is overlapped by the active area; and

first, second, and third adhesive layers, wherein the first adhesive layer is interposed between the first polymer layer and the active area of the flexible substrate and attaches the first polymer layer to the active area of the flexible substrate, wherein the second adhesive layer is interposed between the second polymer layer and the inactive area of the flexible substrate and attaches the second polymer layer to the inactive area of the flexible substrate, and wherein the third adhesive layer is interposed between the first and second polymer layers and attaches the first and second polymer layers together.

2. The display defined in claim 1 wherein the flexible substrate is a polyimide substrate with a thickness of less than 16 microns.

3. The display defined in claim 1 wherein the flexible substrate is a polyimide substrate with an elasticity of less than 5 GPa.

4. The display defined in claim 1 wherein the flexible substrate is coated with a coating layer in the bend region that has an elasticity of more than 0.7 GPa.

5. The display defined in claim 4 wherein the flexible substrate is a polyimide substrate.

6. The display defined in claim 5 wherein the flexible substrate has a thickness of less than 16 microns.

7. The display defined in claim 1 wherein the first and second polymer layers have respective first and second edges at the bend region that are aligned with each other.

8. The display defined in claim 1 wherein the first and second polymer layers have respective first and second edges and wherein the second adhesive layer has a protruding portion that extends from between the first and second polymer layers past the first and second edges.

9. The display defined in claim 8 wherein the protruding portion contacts a surface of the flexible substrate.

10. The display defined in claim 9 wherein the first and second edges are aligned with each other.

11. The display defined in claim 1 wherein the first and second polymer layers have respective first and second edges at the bend region that are not aligned with each other.

12. The display defined in claim 1 wherein the array of pixels comprises an array of organic light-emitting diode pixels.

13. A display, comprising:
 a flexible substrate having opposing first and second surfaces;
 an array of pixels that form an active area on the first surface of the flexible substrate, wherein the flexible substrate is folded at the bend region; and
 at least one layer of material that is attached between a first portion of the second surface of the flexible substrate and a second portion of the second surface of the flexible substrate.

14. The display defined in claim **13** wherein the at least one layer of material comprises first and second polymer layers that are attached between the first portion of the second surface and the second portion of the second surface using adhesive.

15. The display defined in claim **14** further comprising metal traces that extend from the active area to an inactive area on the flexible substrate across the bend region., wherein the inactive area is free of pixels.

16. The display defined in claim **15** wherein the adhesive includes a layer of adhesive between the first and second polymer layers and wherein the layer of adhesive has a protruding portion that protrudes from between the first and second polymer layers and that contacts the flexible substrate.

17. The display defined in claim **13** wherein the array of pixels comprises an array of organic light-emitting diode pixels.

18. The display defined in claim **17** wherein the flexible substrate is coated with a coating layer in the bend region.

19. An organic light-emitting diode display, comprising:
 thin-film transistor circuitry that forms an array of pixels;
 a flexible substrate having a first surface on which the thin-film transistor circuitry is formed and having an opposing second surface, wherein the flexible substrate is bent back on itself so that a first portion of the second surface faces a second portion of the second surface; and
 at least one polymer layer and at least one layer of adhesive that attach the first portion to the second portion.

20. The organic light-emitting diode defined in claim **19** wherein the flexible substrate is bent in a bent region, wherein the at least one polymer layer comprises first and second polymer layers, and wherein the at least one layer of adhesive includes adhesive between the first and second polymer layers that attaches the first polymer layer to the second polymer layer.

21. Apparatus, comprising:

a flexible substrate;

circuitry on the flexible substrate in a first area;

metal traces that extend from the first area to a second area on the flexible substrate across a bend region on the flexible substrate, wherein the flexible substrate is folded over against itself at the bend region so that the first area overlaps the second area;

first and second polymer layers interposed between the first area and the second area that is overlapped by the first area; and

first, second, and third adhesive layers, wherein the first adhesive layer is interposed between the first polymer layer and the first area of the flexible substrate and attaches the first polymer layer to the first area of the flexible substrate, wherein the second adhesive layer is interposed between the second polymer layer and the second area of the flexible substrate and attaches the second polymer layer to the second area of the flexible substrate, and wherein the third adhesive layer is interposed between the first and second polymer layers and attaches the first and second polymer layers together.

22. The apparatus defined in claim **21** wherein the flexible substrate is a polyimide substrate with a thickness of less than 16 microns.

23. The apparatus defined in claim **21** wherein the flexible substrate is a polyimide substrate with an elasticity of less than 5 GPa.

24. The apparatus defined in claim **21** wherein the flexible substrate is coated with a coating layer in the bend region that has an elasticity of more than 0.7 GPa.

25. The apparatus defined in claim **21** wherein the flexible substrate is a polymer substrate and wherein the circuitry in the first area comprises an array of display pixels.

26. The apparatus defined in claim **21** wherein the flexible substrate is a polymer substrate and wherein the circuitry in the first area comprises an array of sensor structures.

27. The apparatus defined in claim **21** wherein the first and second polymer layers have respective first and second edges and wherein the second adhesive layer has a protruding portion that extends from between the first and second polymer layers past the first and second edges.

* * * * *

专利名称(译)	柔性显示面板与弯曲基板		
公开(公告)号	US20160204366A1	公开(公告)日	2016-07-14
申请号	US14/987129	申请日	2016-01-04
[标]申请(专利权)人(译)	苹果公司		
申请(专利权)人(译)	苹果公司.		
当前申请(专利权)人(译)	苹果公司.		
[标]发明人	ZHANG ZHEN TAO YI DRZAIC PAUL S WURZEL JOSHUA G		
发明人	ZHANG, ZHEN TAO, YI DRZAIC, PAUL S. WURZEL, JOSHUA G.		
IPC分类号	H01L51/00 H01L51/52 H01L27/32		
CPC分类号	H01L51/0097 H01L51/004 H01L2251/558 H01L51/5253 H01L2251/5338 H01L27/3276 G09F9/33 H01L27/32 H01L27/3244 H01L27/3246 Y02E10/549 H01L23/4985 H01L23/5387 H01L27/326		
优先权	62/102284 2015-01-12 US		
其他公开文献	US9614168		
外部链接	Espacenet USPTO		

摘要(译)

显示器可以具有有机发光二极管阵列，其在柔性基板上形成有源区域。金属迹线可以在有源区域和柔性衬底的无源区域之间延伸。诸如显示驱动器集成电路的显示驱动器电路可以耦合到非活动区域。金属迹线可以延伸穿过柔性基板中的弯曲区域。柔性基板可以在弯曲区域中弯曲。柔性基板可以由薄的柔性材料制成，以减少金属迹线弯曲应力。弯曲区域中的涂层可以具有增强的弹性，以允许其厚度减小。柔性基板可以自身弯曲并且在不使用心轴的情况下固定在电子设备内。

